

# ATEKO a.s.

1949 – 2020

*Syngas Treatment Equipment*

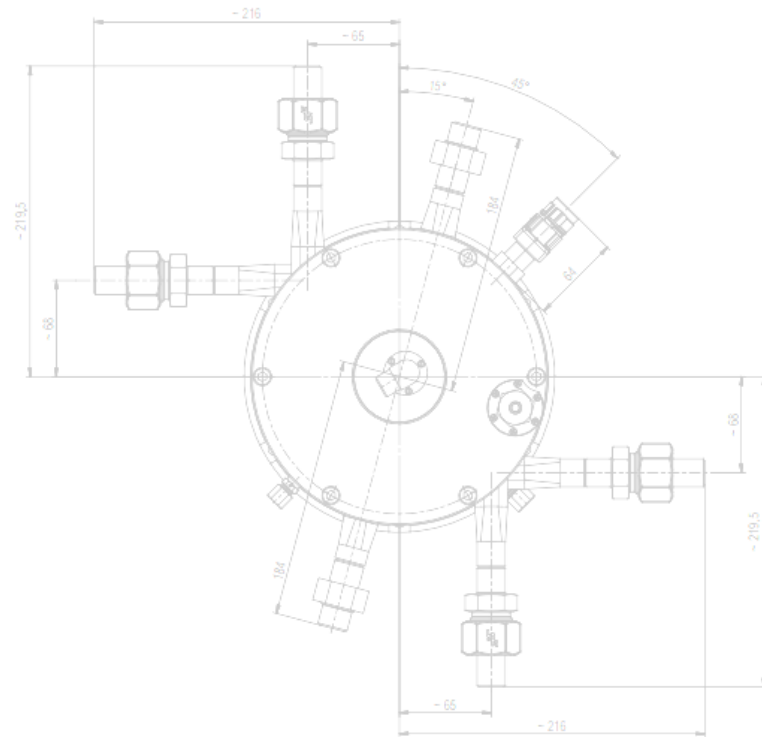

# Syngas Treatment Technology – Current Approach

## ***Current Technology:***

### **General Feature:**

- **Narrow focus on one type of treated gas or limited extent group of gaseous product**

## ***Current Ways:***

- ***Absorption agent***
- ***Coke oven gas cleaned using sodium hydroxide***
- ***Membrane separation***

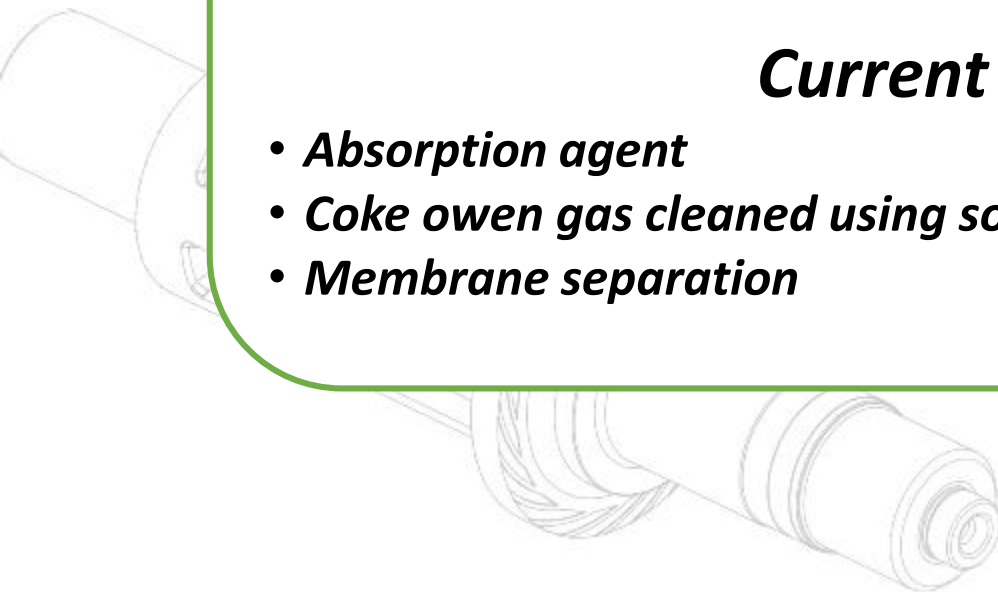
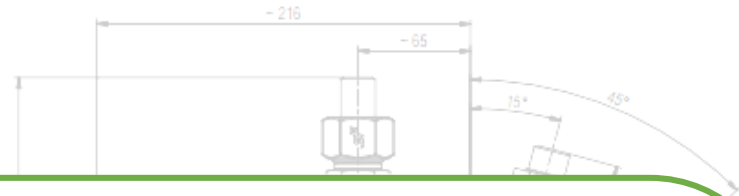

## ***A New Solution Proposal:***

**Design based on set of isolated subsystems according to treated syngas qualities**

### ***Composed of:***

- 1. Separation of solid pollutants**
- 2. Syngas cooling**
- 3. Tar removal absorption unit**
- 4. Removal of acidic components (Sulfur and Chlorine) absorption unit**
- 5. Preheating of treated syngas**
- 6. After treatment unit**
- 7. Control and monitoring system**

# ATEKO Syngas Cooling & Treatment System ASCTS 2

**Functional  
Demo  
Unit**

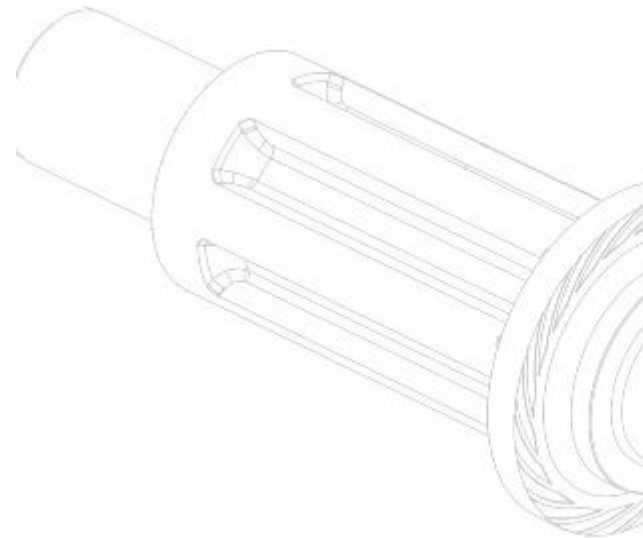
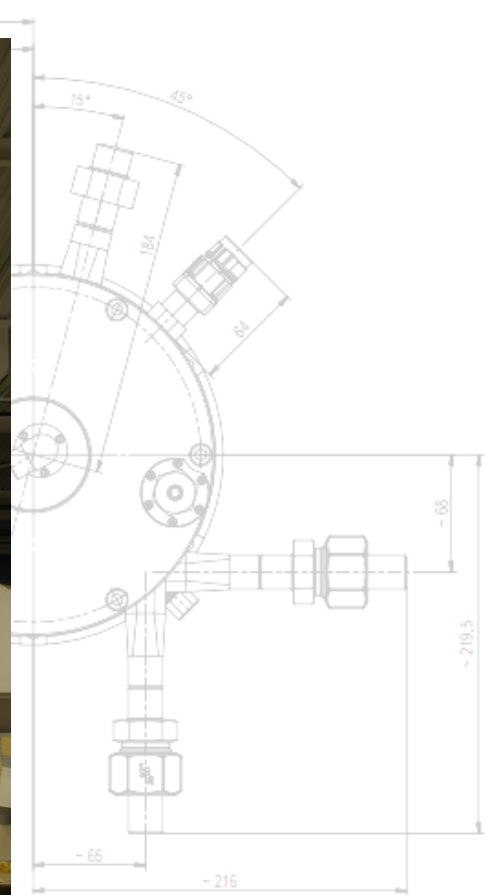

# ATEKO Syngas Cooling & Treatment System ASCTS 3

## ASCTS Process Flow Diagram

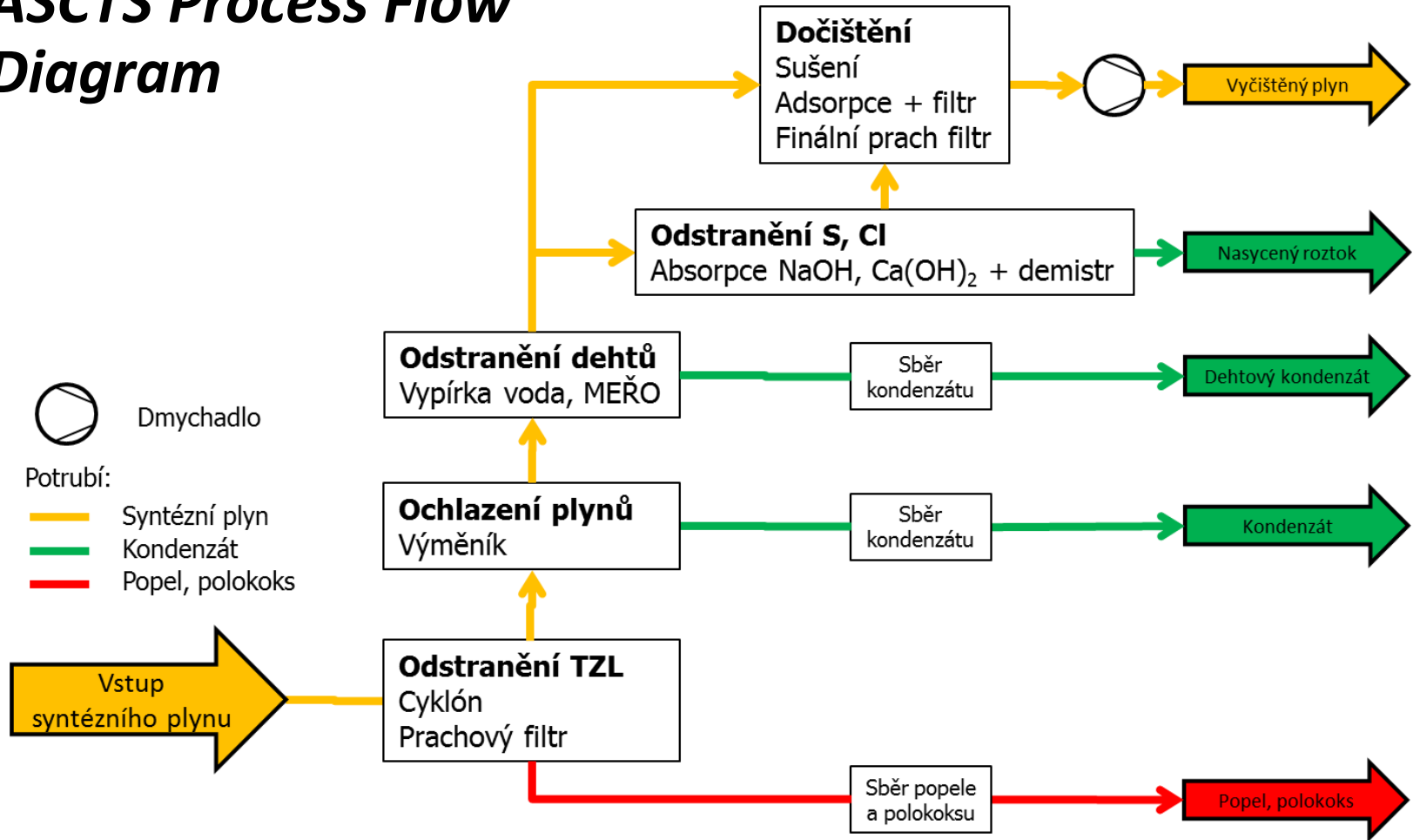

# ATEKO Syngas Cooling & Treatment System ASCTS 4

- **Single subsystems are designed and employed according to syngas qualities and amount**
- **Side effect of syngas cooled in column by washing liquid**
- **Siemens S-7 Control Unit**

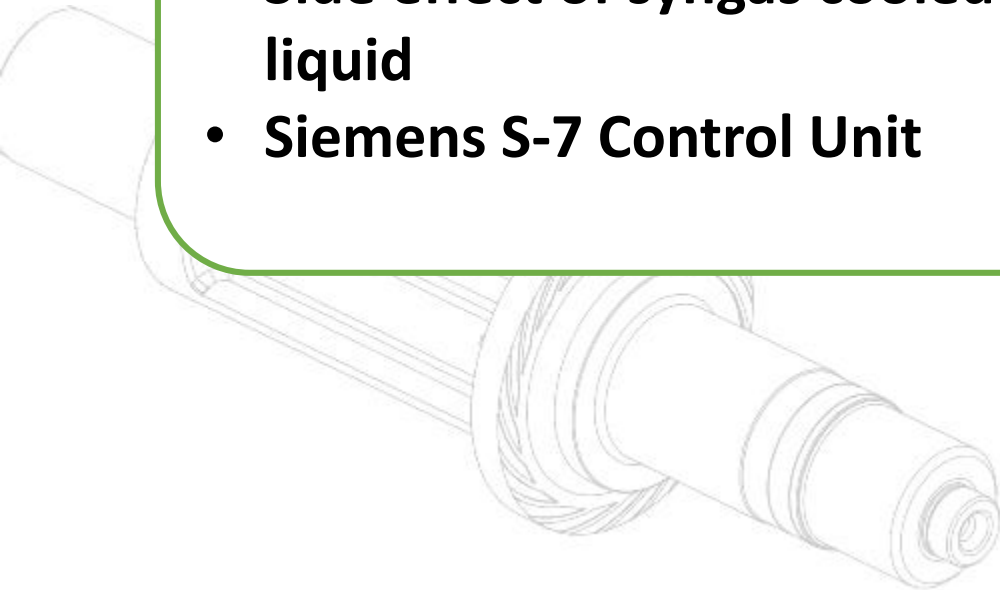
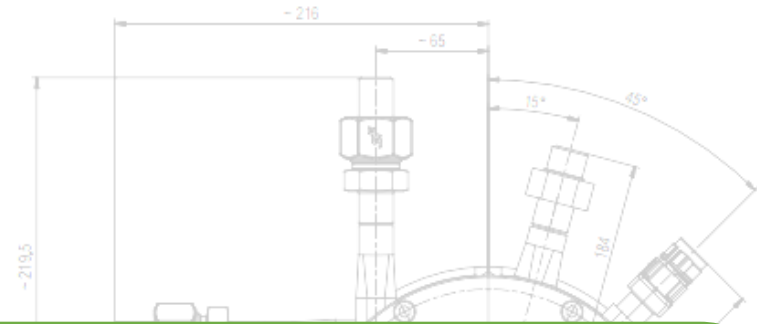

# ATEKO Syngas Cooling & Treatment System ASCTS 5

## ***Process Products:***

- **Outlet gas**  
*(free of ash, tar, sulfur compounds, reduced water content due to lower temperature)*
- **Water condensate**
- **Tar condensate**
- **Saturated absorbent solution**
- **Ash and semi-coke**  
*(if a cyclone or other separator type is installed)*

# ATEKO Syngas Cooling & Treatment System ASCTS 6

- Usable for biomass combustion
- Gasification
- Pyrolysis
- Coking
- Treated syngas may be used in cogeneration units
- Verified in cooperation with Technical University Ostrava

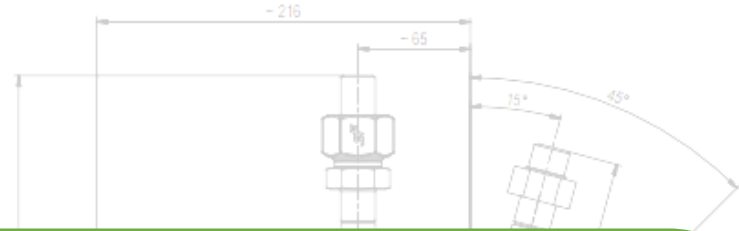



*Thank you for your attention*

<http://www.ateko.cz>

[ateko@ateko.cz](mailto:ateko@ateko.cz)

